



Power Transmission

2018優良商標獎

球型分体聯軸器

MAX DYNAMIC & FIELD COUPLINGS



拓宇传动件(广州)有限公司

销售中心：广州市白云区丛云路816号B903
工厂地址：广州市白云区太和镇南岭工业区A栋1楼
电话：+86 020-86088846 传真：+86 020-86088849
E-mail：lwt@topyultd.com



台灣總部

捷鉞興業有限公司

台南市仁德區文華路三段428巷152弄16號
TEL：06-2791658 FAX：06-2791657
E-mail：power.jetchen@msa.hinet.net
www.jetchen.com.tw



Max Dynamic & Field Couplings Types

Max Dynamic Couplings



D Type



DS Type (Spacer)

Max Field Couplings



F Type



FS Type (Spacer)

D Type

Standard Type

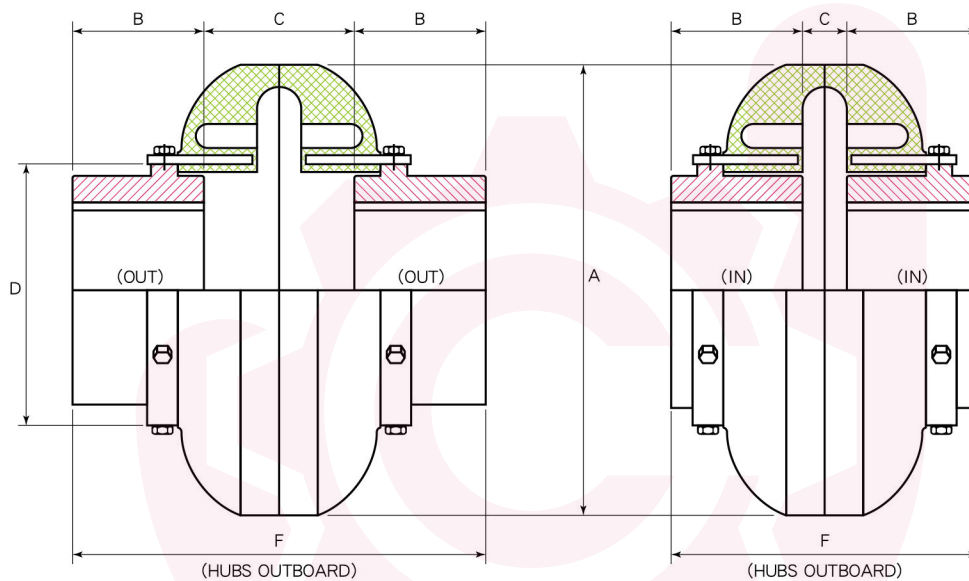

規格	定額 扭矩 (Nm)	最高 轉速 (RPM)	功率 (KW)	重量 (Kg)	最大 孔徑 (mm)	最小 孔徑 (mm)	尺寸 / mm						
							A	B	C		D	F	
									In	Out		In	Out
2	21.5	7,500	0.0023	0.55	28	13	89	24	35	47	47	83	95
3	41.2	7,500	0.0043	1.10	34	13	102	37	9	47	59	83	121
4	62.0	7,500	0.0066	1.40	42	13	116	37	9	47	66	83	121
5	104.5	7,500	0.0110	2.50	48	13	137	45	10	52	80	100	142
10	163.8	7,500	0.0170	3.70	55	13	162	45	11	53	93	101	143
20	260.0	6,600	0.0270	5.90	60	21	184	50	15	63	114	115	163
30	412.0	5,800	0.0430	9.60	75	21	210	56	12	68	138	124	180
40	622.0	5,000	0.0660	15.90	85	26	241	61	12	74	168	134	196
50	864.0	4,200	0.0900	24.50	90	26	279	69	12	86	207	150	224
60	1,412.0	3,800	0.1480	32.80	105	31	318	80	11	99	222	171	259
70	2,486.0	3,600	0.2620	39.00	120	31	356	85	18	109	235	189	281
80	4,463.0	2,000	0.4670	77.00	155	31	406	114	17	147	286	245	377
100	9,605.0	1,900	1.0000	111.00	171	48	533	140	44	95	359	324	375
120	19,221.0	1,800	2.0000	193.00	190	48	635	152	57	124	448	362	429

*Coupling Weight is without Bore Machining

DS Type

Spacer Type

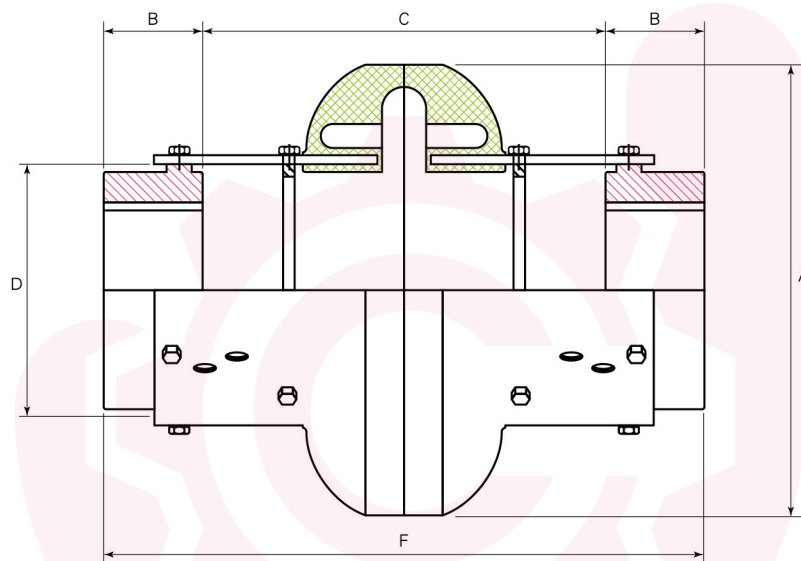

規格	定額 扭矩 (Nm)	最高 轉速 (RPM)	功率 (KW)	重量 (Kg)	最大 孔徑 (mm)	最小 孔徑 (mm)	尺寸 / mm						
							A	B	C (Gap)		D	F	
									In	Out		In	Out
2	21.5	7,500	0.0023	1.0	28	13	89	24	91	100	47	146	149
3	41.2	7,500	0.0043	1.8	34	13	102	37	85	140	59	184	216
4	62.0	7,500	0.0066	2.3	42	13	116	37	85	140	66	184	216
5	104.5	7,500	0.0110	3.4	48	13	137	45	89	140	80	184	228
10	163.8	7,500	0.0170	4.7	55	13	162	45	89	140	93	184	228
20	260.0	4,800	0.0270	7.1	60	21	184	50	67	180	114	238	280
30	412.0	4,200	0.0430	11.4	75	21	210	56	54	180	138	238	293
40	622.0	3,600	0.0660	18.2	85	26	241	61	41	180	168	238	307
50	864.0	3,100	0.0900	27.3	90	26	279	69	28	180	207	238	319
60	1,412.0	2,800	0.1480	38.2	105	31	318	80	66	250	222	318	415
70	2,486.0	2,600	0.2620	46.4	120	31	356	85	59	250	235	318	421
80	4,463.0	1,800	0.4670	81.8	155	31	406	114	37	250	286	318	478

*Coupling Weight is without Bore Machining

F Type

Standard Type

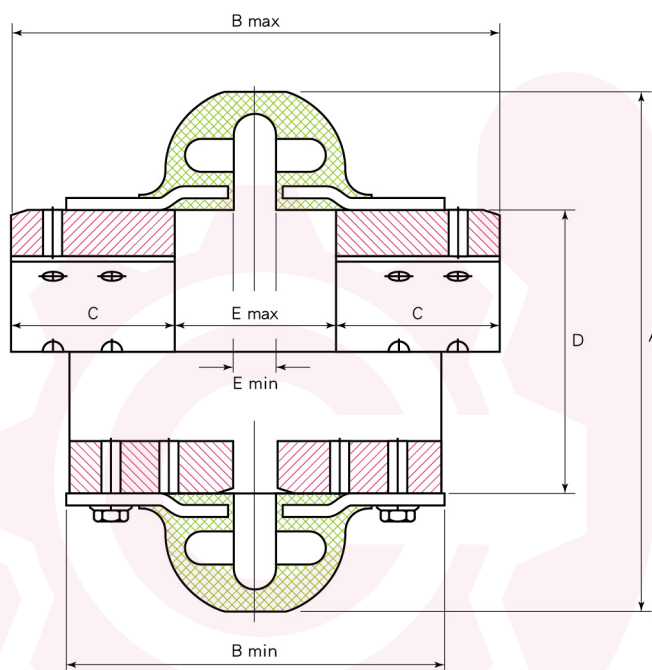

規格	定額 扭矩 (Nm)	最高 轉速 (RPM)	重量 (Kg)	最大 孔徑 (mm)	最小 孔徑 (mm)	尺寸 / mm						
						A	B		C	D	E	
							Max	Min			Max	Min
110	64	5,400	0.474	38	10	110	128	96	38	60	52	8
125	106	5,400	0.550	48	10	120	130	97	38	70	52	8
130	170	5,100	0.700	55	11	131	131	95	41	80	49	7
150	256	4,800	1.020	65	11	150	159	111	51	95	57	9
170	312	4,800	1.196	65	11	168	159	111	51	95	57	9
190	420	4,600	1.526	75	19	190	161	113	52	117	57	7
215	670	4,300	2.506	80	19	216	192	132	64	140	64	11
245	970	4,100	3.080	95	19	245	203	136	65	171	73	8
290	1,450	3,900	4.500	110	27	290	240	154	73	215	94	8
365	3,300	3,600	11.800	127	35	365	311	200	90	235	131	20
425	5,700	2,000	14.800	155	35	425	361	247	114	286	133	19
460	6,400	2,000	17.200	165	48	460	380	267	124	302	132	19

*Coupling Weight is without Bore Machining

FS Type

Spacer Type

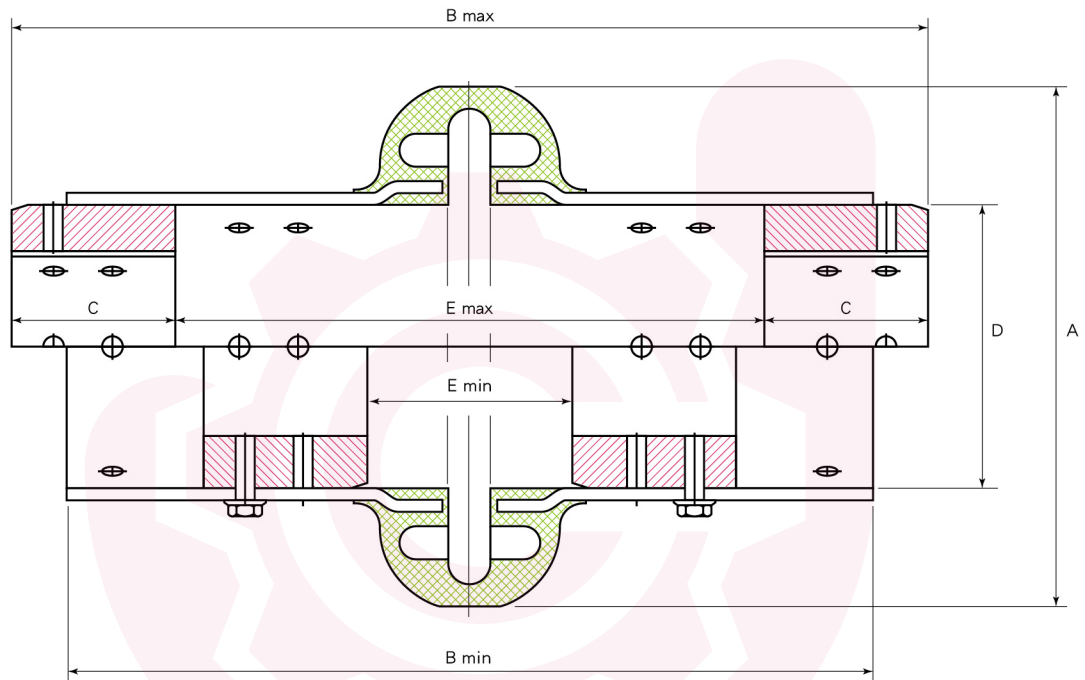

規格	定額 扭矩 (Nm)	最高 轉速 (RPM)	重量 (Kg)	最大 孔徑 (mm)	最小 孔徑 (mm)	尺寸 / mm						
						A	B		C	D	E	
							Max	Min			Max	Min
110	64	4,300	0.764	38	10	110	213	180	38	60	137	41
125	106	4,300	0.920	48	10	120	220	187	38	70	144	52
130	170	4,200	1.130	55	11	131	214	179	41	80	132	49
150	256	4,000	1.760	65	11	150	276	232	51	95	174	57
170	312	4,000	1.940	65	11	168	276	232	51	95	174	57
190	420	3,900	2.500	75	19	190	278	232	52	117	174	57
215	670	3,800	4.100	80	19	216	309	248	64	140	181	57
245	970	3,700	5.180	95	19	245	323	256	65	171	193	66
290	1,450	3,600	8.540	110	27	290	401	312	73	215	255	72
365	3,300	2,600	15.440	127	35	365	428	318	90	235	250	76
425	5,700	1,800	19.320	155	35	425	478	318	114	286	250	68
460	6,400	1,800	22.080	165	48	460	498	318	124	302	250	67

*Coupling Weight is without Bore Machining